

Intellivent ICE

Intellivent ICE is a bathroom fan loaded with ingenious sensors to give you a healthy and comfortable environment in the bathroom, toilet and laundry room.

- **Unique air quality sensor**
- **Intelligent and self-adjusting humidity control**
- **Superior pressure performance**
- **Fine tuning with touch panel or app connectivity**
- **Light sensor for timer start**



Specifikation

Article codes

Art no:	197406
EAN 13:	7318111974060
ETIM:	EC001141

Measurement

Channel dimension Ø :	100 mm, 120 mm, 125 mm
Product Width:	185 mm
Product Height:	160 mm
Product Depth:	67 mm
Product Weight:	0.4 kg

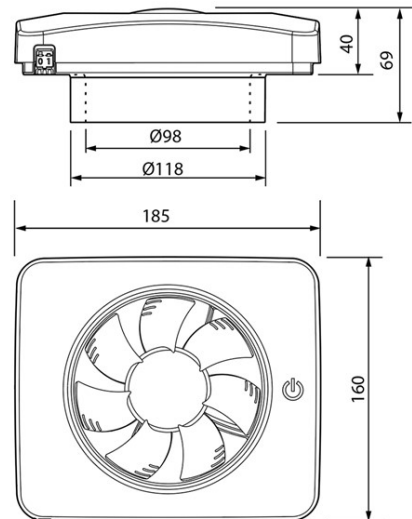

Characteristics

Functions:	Run on timer, Intelligent humidstat, Constant flow, Light sensor, Odour sensor, Timer, Switch live
Installation Type, Wall, Ceiling Etc:	Horizontal, Vertical
Maximum Pressure:	57 Pa
Free To Air Max (m3/h):	140 m ³ /h
Max Watt(W):	5 W
Supply Voltage (12V-400V):	100V AC, 110V AC, 230V AC
Electrical Supply Phase:	1-Phase
Insulation Class:	II (shall not be protectively grounded)
Type Of Motor:	EC
Wireless Control Option:	Bluetooth LE
Protection (Ip):	IP 44
Finish:	Gloss
Colour:	White
Material:	Plastic
Plastic Material Detail:	ABS
Maximum Operating Temperature:	50 °C
Minimum Operating Temperature:	0 °C
Warranty Number Of Years:	5 years

Description/Function

Intelligent ventilation

With a unique odour sensor, unrivalled extraction capacity, and advanced moisture control, Intellivent ICE is optimised to produce a fresh and comfortable bathroom climate.

Air quality sensor

Intellivent ICE is the only bathroom fan in the world equipped with an air quality sensor that is able to detect strong odours. When the sensor detects a strong odour, the fan speed increases and quickly neutralises the odour to ensure the air always feels fresh.

Superior pressure performance

The fan is completely unrivalled when it comes to extraction capacity, which means it can cope with long ducts and bends without compromising ventilation.

Self-adjusting humidity control

Intellivent ICE has a fully automatic humidity control, which means it activates automatically when it detects an elevated moisture level. When the moisture in the room increases, the fan increases its airflow to ensure that the climate in the bathroom remains comfortable.

Extremely quiet

Although Intellivent ICE is equipped with a new, significantly more powerful motor than all its predecessors, the fan is almost silent.

Autonomous

Another one of Intellivent ICE smart features is its light sensor. The fan recognises when you enter a room and activates. This means that, together with the aeration program that starts after the fan has been idle for 26 hours, the fan is fully autonomous. The fan is therefore ideal for any areas subjected to moisture and odours. Perfect for bathrooms, basements, or summerhouses.

Touchscreen

An intuitive and unique touchscreen activates when you touch the On/Off button. The fan's most important functions can be controlled from here. When you are finished, the screen dims and becomes virtually invisible again. And the fan can be restored to the default factory settings through the simple push of a button.

Fine-tuning via the App

With our Fresh Ventilation Bluetooth app, you can customise multiple functions according to your particular conditions. This is highly practical if the fan is mounted in the ceiling and the touchscreen is hard to reach.

Simple installation

Thanks to its practical design and cable quick-connectors, Intellivent ICE is easy to both mount and install. When you want to clean the fan, the impellor can be easily removed with one hand. The fan is certified for both ceiling and wall installation.

Developed, designed and manufactured in Sweden

Intellivent ICE is the bathroom fan of the future, and it is the product of expert craftsmanship, past experience, accuracy and precision. Swedish-made quality with technology and design in perfect harmony.

Design front





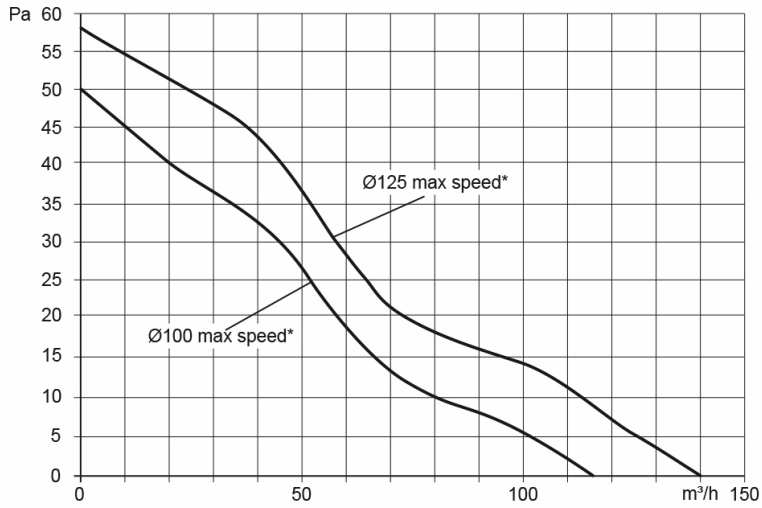





The design front is easily placed on the fan with magnetic attachment.

Capacity



*Values for fan without Design front

Accessories

	Product	Stock code
	Wall pipe D118/122x150	185150
	Wall pipe D98/102x100	188010
	Through wall kit Intellivent YVG D125	197245
	Intellivent cover plate, white	197430
	Through wall kit Fresh YVG D100	629703
	Backdraught protection D98	669801
	Backdraught protection D125	669812
	Hole saw D127	804044
	Chuck D32-210	804046
	Chuck extender D32-210	804048