





Ventilair Cálma

Centralized Energy Recovery System



Más inteligente

New structure and intelligent control

-  Operation even at low temperatures
-  Balanced pressure
-  Advanced sleep function
-  Intelligent air flow compensation



Ventilair Calma

Centralized Energy Recovery System to improve indoor air quality.



Health

- Reducing the risk of viruses such as COVID-19 and other respiratory infections that spread through the air.
- Improving productivity, comfort, and cognitive performance by alleviating stress and Sick Building Syndrome.
- Designed to mitigate risks associated with environmental pollution, promoting a healthier environment and reducing the incidence of cardiovascular and pulmonary diseases.



Saves energy costs

- Reducing energy consumption and HVAC equipment capacity by transferring heat and humidity between outgoing and incoming air streams.
- Complies with ventilation and energy standards for sealed buildings that cannot rely solely on natural ventilation.
- Increasing comfort and visitor dwell time during leisure activities in commercial buildings that offer healthy indoor air. Extending the HVAC system's life.



Comfort

- Reduction of humidity, contaminants, and stale air that can cause uncomfortable health problems.
- Maintaining an appropriate indoor relative humidity level, regardless of outdoor conditions.



Easy maintenance and care

- For maintenance, heat exchangers and filters are removable; filters are washable.

Better indoor air quality and lower energy consumption

The **Energy Recovery System** installed on the **Calma** introduces clean, fresh air indoors and expels contaminated air to the outside, renewing your home instantly.

This system optimizes your home's climate using two smart modes:

Bypass Mode: When the outdoor climate is pleasant, it introduces fresh air directly and extracts stale air without activating heat exchange, naturally renewing the environment.

Energy Recovery Mode: During winter and summer, the system exchanges energy between air streams to maintain thermal comfort, drastically reducing electricity consumption.

Technology and Health

Thanks to its high-efficiency heat exchanger and compact precision filter, this unit guarantees a healthier home by removing contaminants and renewing stale air with minimal energy expenditure.

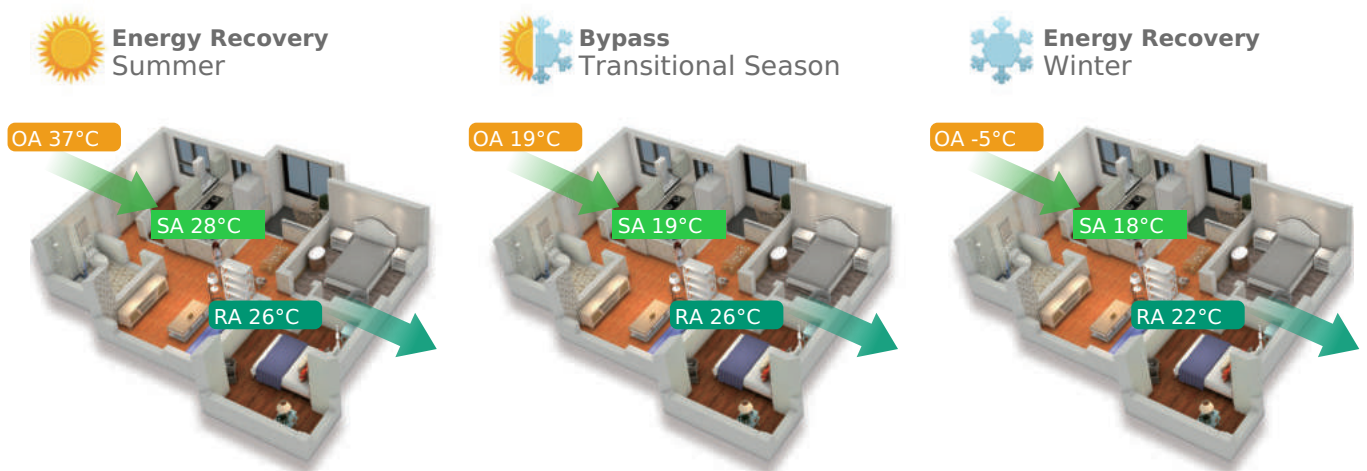

Ventilair Calma

Centralized Energy Recovery System



Calma150C-1000C



Calma1500C-2000C



CHARACTERISTICS

- Wide air flow range: from 150 to 2000 m³/h.
- Encapsulated plastic DC motor, 10 speeds.
- Supply air purification with primary filter (G3) and optional intermediate filter (F7).
- Edge sealing technology.
- High-efficiency total heat exchanger of the latest generation.
- Side ports reserved for OA (outside air) and EA (exhaust air), flexible installation.
- Automatic bypass.
- Two installation types to adapt the unit to the room.
- A smarter control system for Android/iOS.
- Energy efficiency class A+ or A according to EU No. 1253/2014.

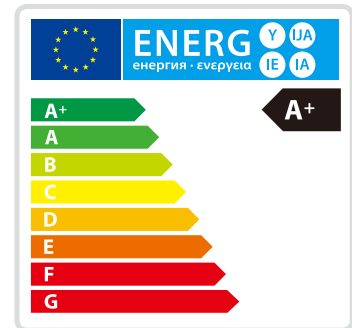

DESIGN

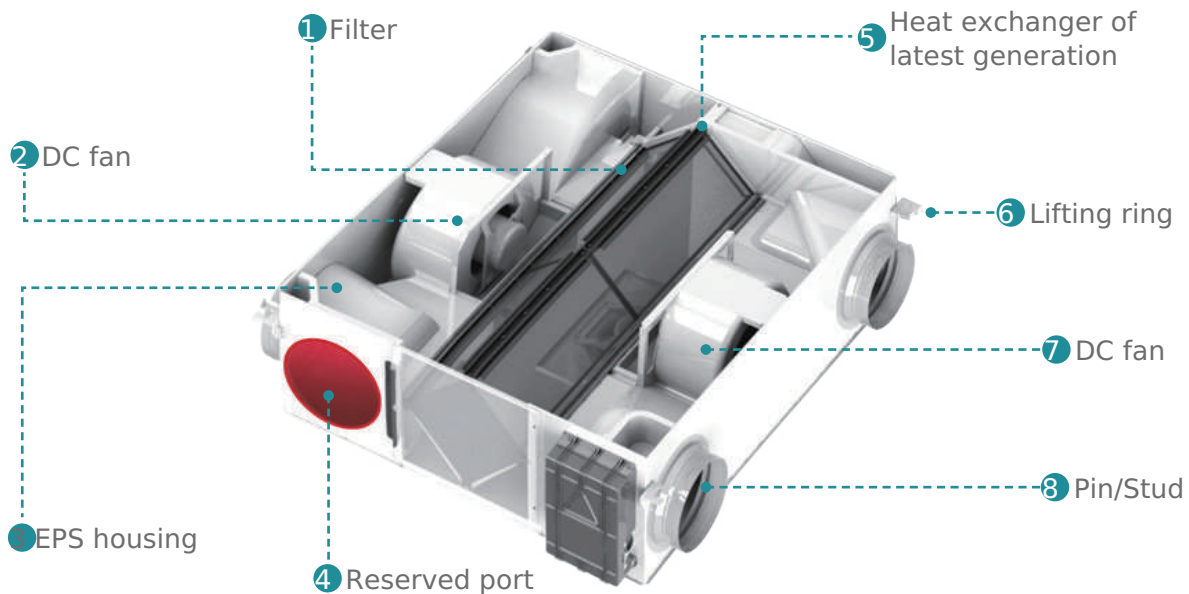

■ CASING

- Easy installation with integrated EPS housing.
- Better insulation, airtightness and noise reduction.
- Fans mounted in central position, with stable airflow for greater heat exchange efficiency and stable operation.

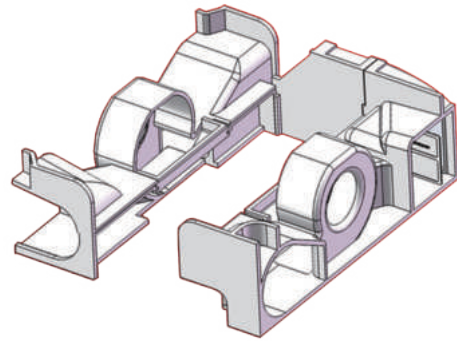

■ FLEXIBLE INSTALLATION

- Parallel airflow rate.
- Available with inverted installation.
- Side ports reserved for OA and EA.

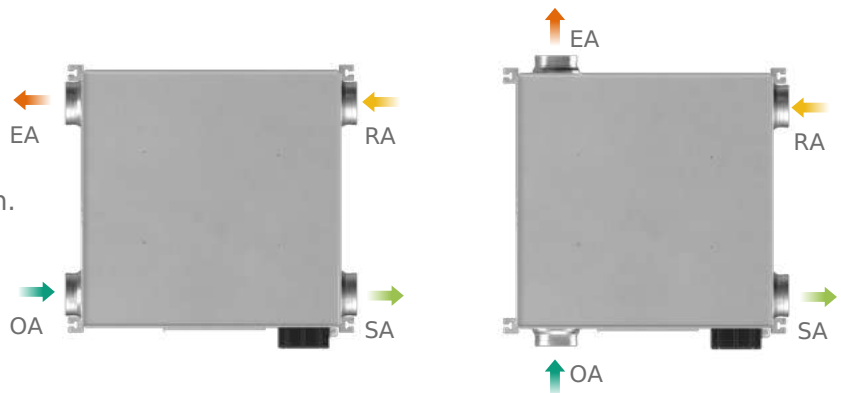

■ EDGE CLOSING TECHNOLOGY

- Triple-folded edge thickness that improves casing strength.
- Higher production efficiency.
- Good appearance and airtightness.

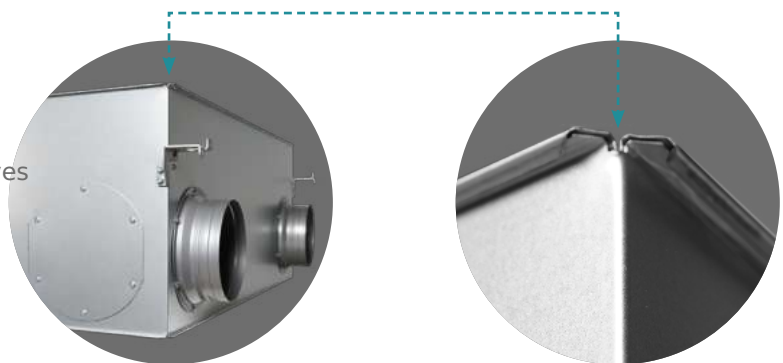

■ NEW DC FANS

Compared to the old AC motor with a metal housing, the new motor operates more stably, quietly, and energy efficiently, saving up to 40%.



saving up to 40%

■ LATEST GENERATION TOTAL HEAT EXCHANGER

- New ER paper with higher heat exchanger efficiency.
- Heat exchange materials are mold-resistant and fire retardant.
- Integrated structure, better tightness and appearance.



Mold resistance and fire protection test certification against fires

■ INTEGRATED FILTER GRILLE

Integrated reserved guide with the primary filter, the medium filter F7 is optional.



Advanced LCD remote control panel



Intelligent Control

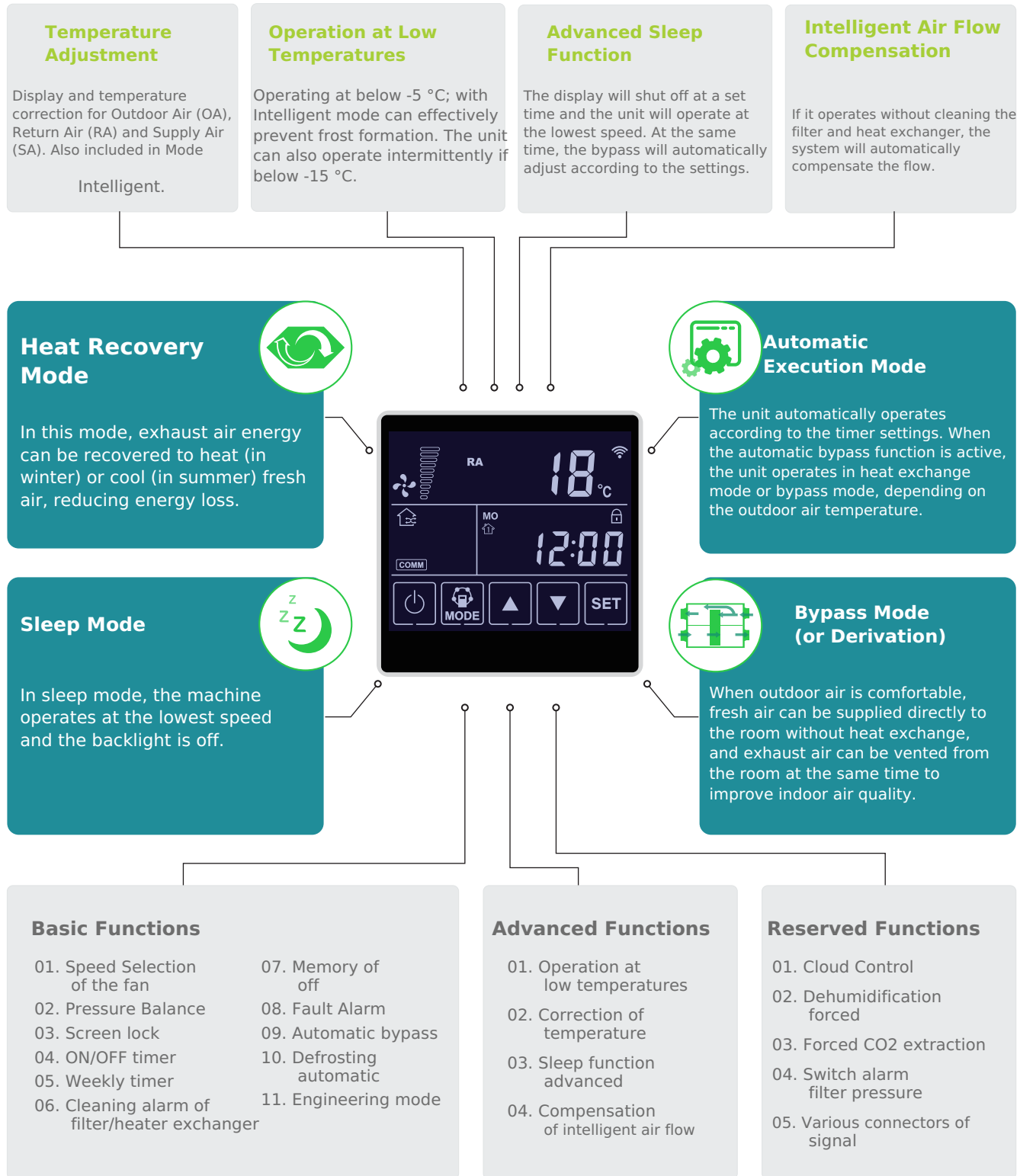

The indoor climate of your home, at your fingertips, with the SMART LIFE app

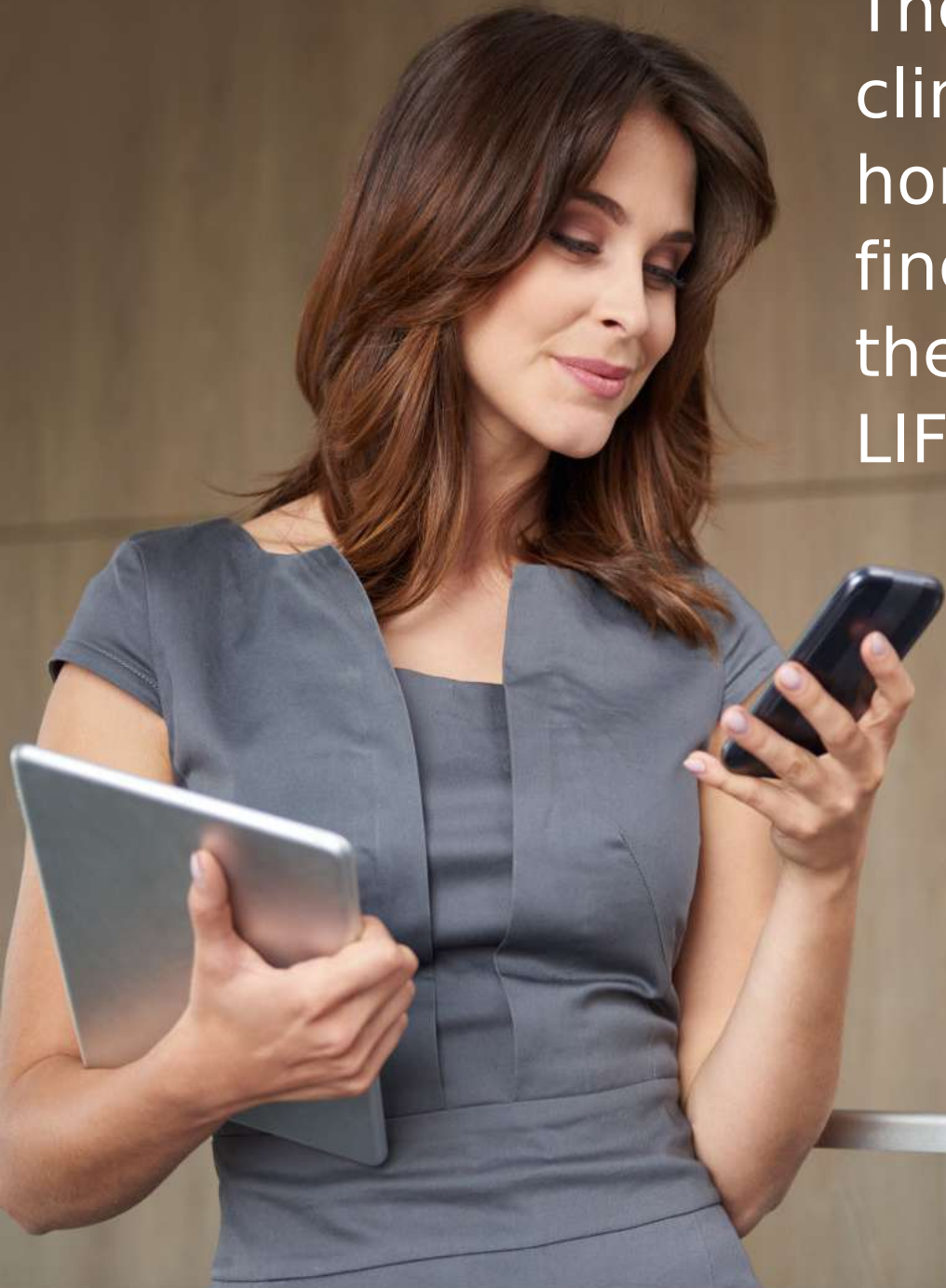

WIFI FUNCTION

Total Control from your Smartphone

Thanks to the WiFi connection, you can manage and monitor your ventilation system from anywhere in the world.

Keeping a healthy home is now easier: monitor indoor air quality in real time and make instant adjustments directly from your phone.

INDOOR AIR QUALITY MONITORING

Total control of your well-being Monitor in real time

- temperature, humidity and CO2 levels. Everything you need to ensure a healthy environment, directly on your mobile.



VARIABLE CONFIGURATION

Easily manage air speed, scheduling, and bypass mode, with automatic alerts for filter maintenance.

GROUP CONTROL

Intelligent Management and Connectivity:

The system automatically adapts to the climate of your area. With one app, you can manage multiple units and synchronize them with other smart devices through the Tuya app.

The SMART LIFE app is available on Google Play and the App Store.

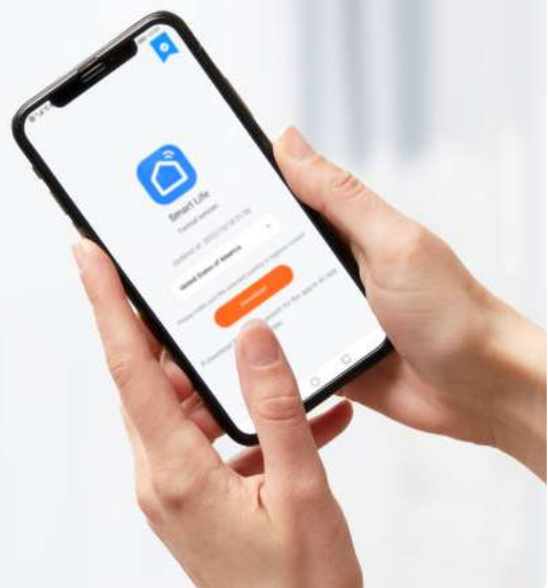

TECHNICAL PARAMETERS



Model	Flow Rate nominal (m³/h)	Pressure external (Pa)	Enthalpy Efficiency (%)		Efficiency thermal (%)	Noise dB(A)	Voltage (V)	Power of input (W)	Net Weight (kg)
			Cooling	Heating					
Calma 150C	150	95	71-79	73-79	80-84	29	220-240	58	20
Calma 250C	250	85	68-83	70-83	79-86	28	220-240	62	23
Calma 350C	350	160	71-82	72-84	80-89	32	220-240	140	30
Calma 500C	500	120	67-82	69-83	78-87	34	220-240	165	33
Calma 650C	650	120	66-81	69-82	77-86	35	220-240	252	38
Calma 800C	800	150	70-81	71-82	79-85	35	220-240	335	48
Calma 1000C	1000	170	71-86	73-87	80-90	37	220-240	420	54



Model	Flow rate nominal (m³/h)	Pressure external (Pa)	Enthalpy efficiency (%)		Efficiency thermal (%)	Noise dB(A)	Voltage (V)	Power of input (W)	Net weight (kg)
			Cooling	Heating					
Calma 1500C	1500	175	71-81	72-82	80-85	39	220-240	670	105
Calma 2000C	2000	150	71-86	73-87	80-90	40	220-240	850	117

* Operating environment range: temperature from -20 °C to 45 °C, relative humidity below 85% RH.

PERFORMANCE GRAPHS

■ Calma 150C

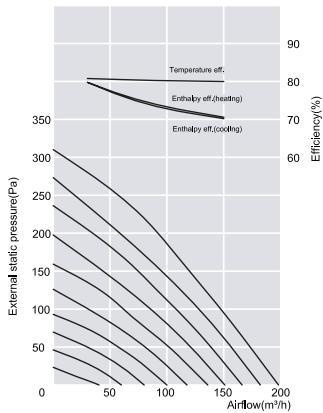

■ Calma 250C

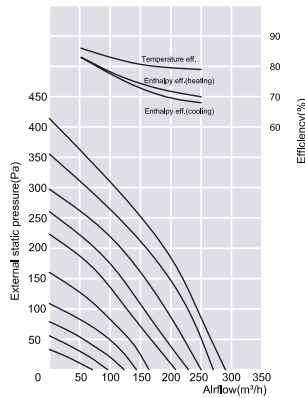

■ Calma 350C

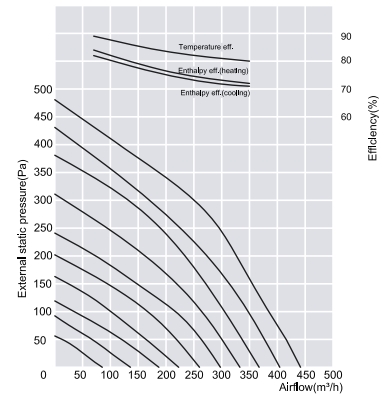

■ Calma 500C

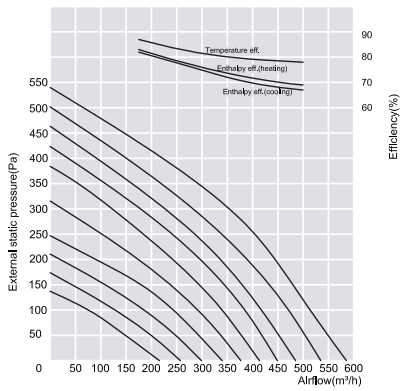

■ Calma 650C

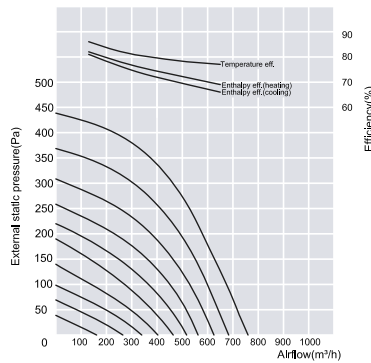

■ Calma 800C

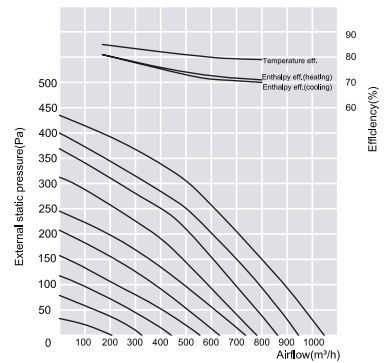

■ Calma 1000C

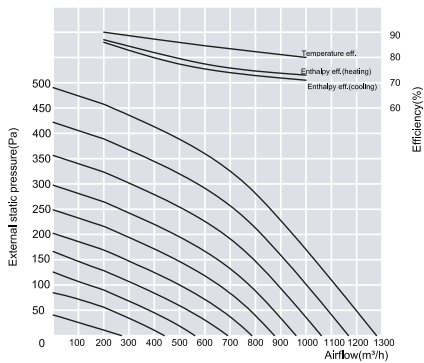

■ Calma 1500C

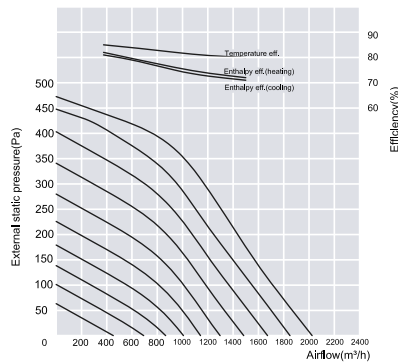

■ Calma 2000C

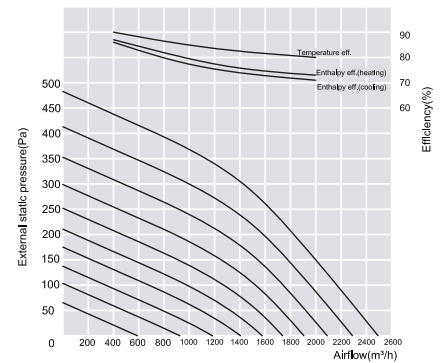

DIMENSIONS

■ Calma 150C-1000C

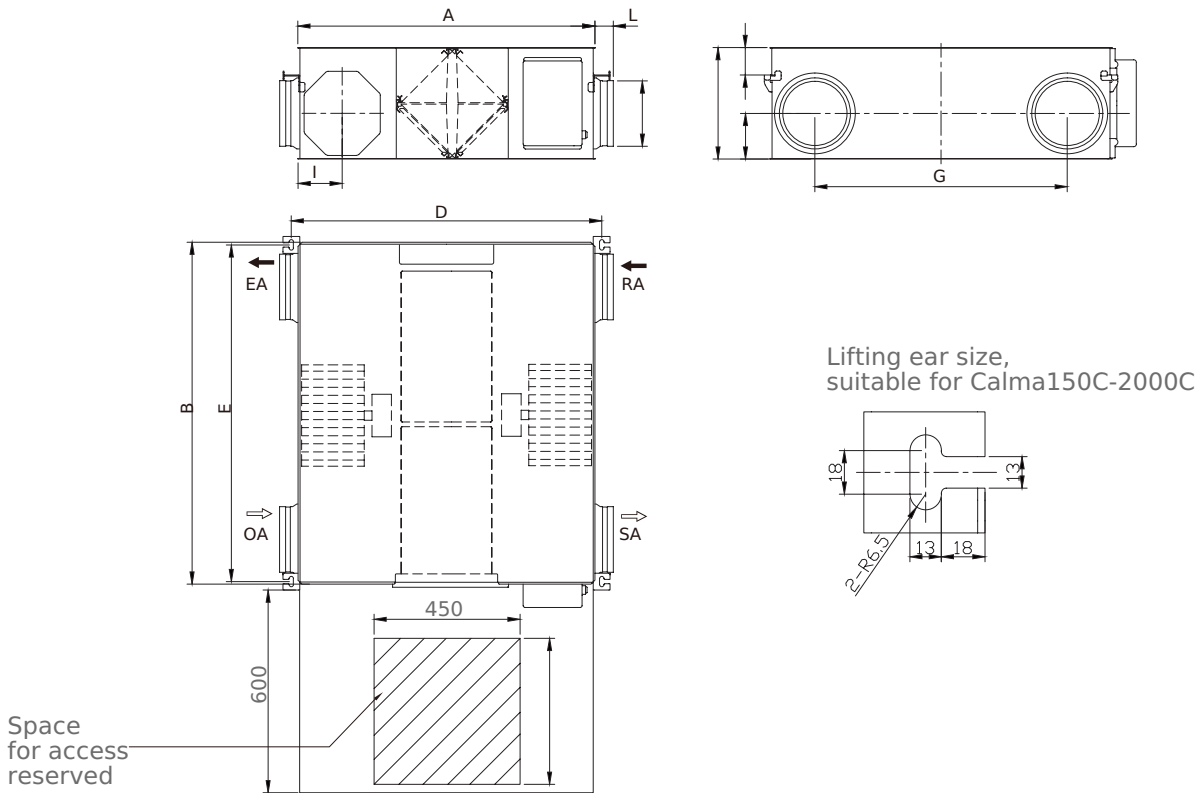

Model	Dimension			Hoist ring size			Distance from the duct			Size of the air inlet/outlet	
	A	B	C	D	E	F	G	H	I	K	L
Calma 150C	780	610	289	819	594	78	450	95	116	95	53
Calma 250C	780	735	289	819	719	78	526	95	116	144	58
Calma 350C	884	874	331	922	858	81	650	135	132	144	58
Calma 500C	884	1016	331	922	1000	81	750	135	132	195	61
Calma 650C	908	954	404	946.5	935	71	692	202	123	195	61
Calma 800C	1144	1004	404	1182	986	82	690	162	164	244	62
Calma 1000C	1231	1231	404	1182	1213	82	917	162	164	244	62

■ Calma 1500C-2000C

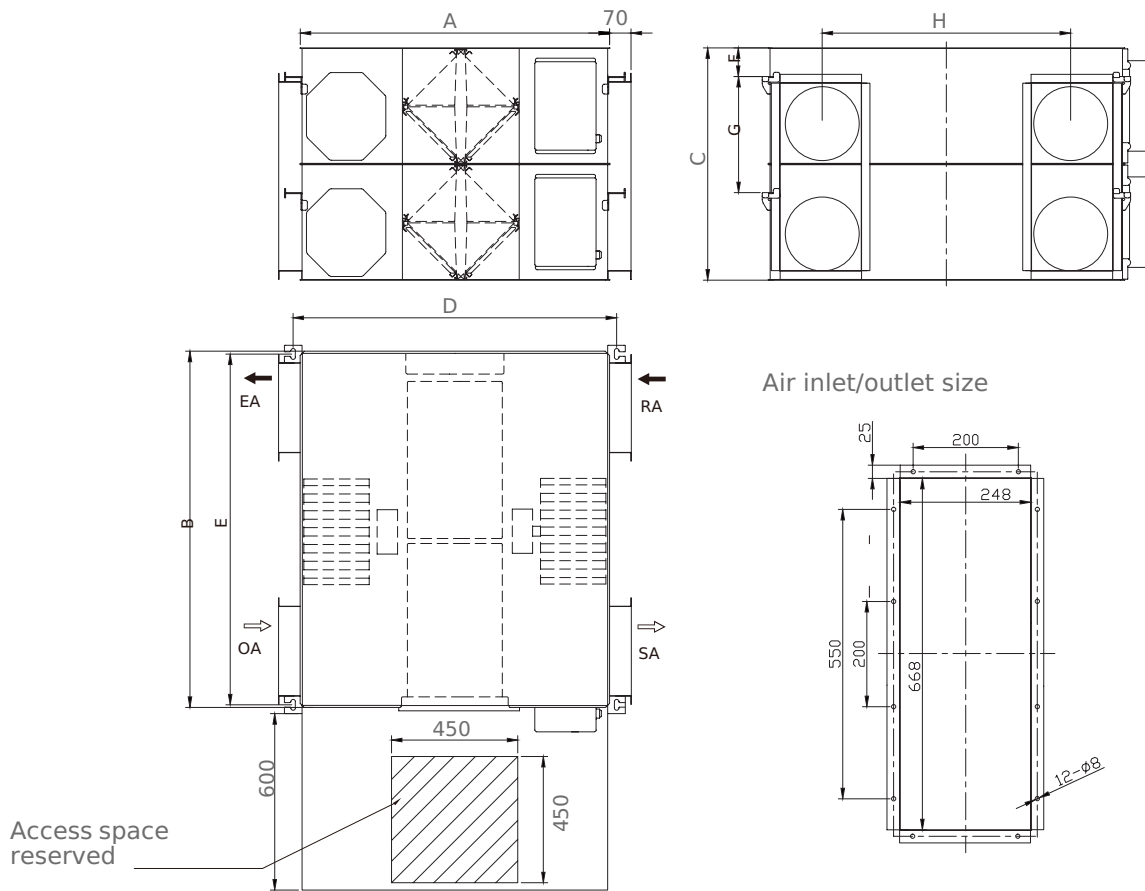

Model	Dimension			Lifting ring size				Distance from duct
	A	B	C	D	E	F	G	H
Calma 1500C	1144	1004	808	1182	986	82	404	690
Calma 2000C	1144	1231	808	1182	1213	82	404	917

■ INSTALLATION DIAGRAM

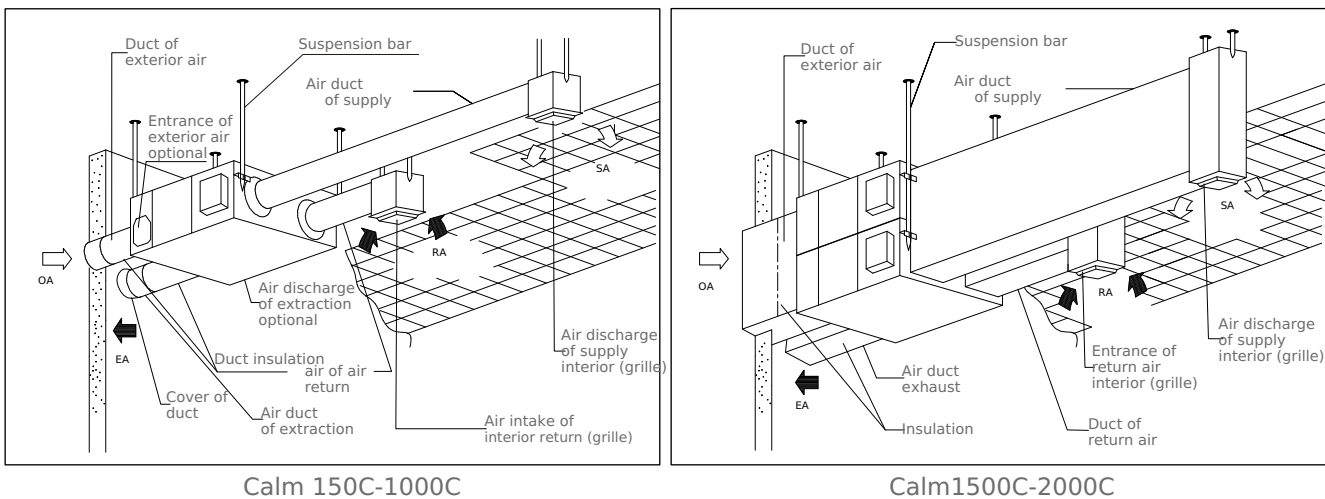

Calm 150C-1000C

Calm1500C-2000C

OTHER ACCESSORIES



Humidity Sensor



CO2 Sensor



Smart Air Quality Detector



WiFi Module

GROUP CONTROL

Group management without limits: The application allows you to group and control all your dispositives simultaneously. There is no limit on units, which lets you manage your entire system with a single tap.

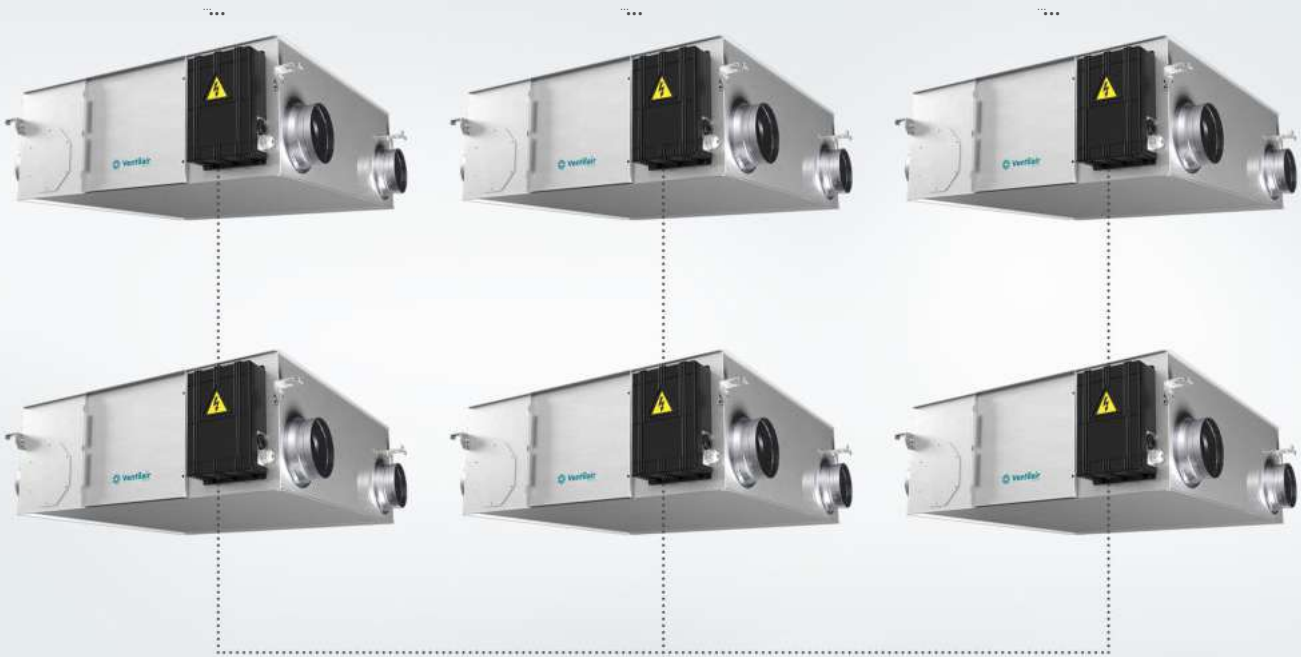
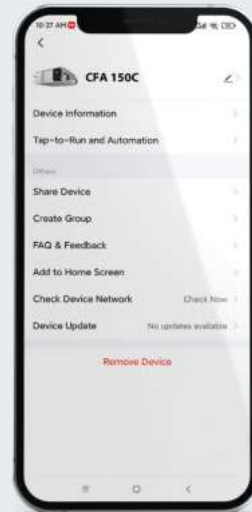

ENVIRONMENTAL CONTROL

Intelligent automation through environment changes:

Configure your system operation based on weather, schedules, or specific device states. For example, you can program the fan to automatically stop if outdoor humidity exceeds 85%, preventing excess humidity from entering your home. Once configured, the unit will manage the environment completely autonomously.



LINKAGE CONTROL

Unified control on your home screen:

Customize your experience by adding all your devices to the Tuya app's main screen. Group your energy recovery devices, fans, extractors and switches in the same room to manage them all together or individually, as needed.





VENTILAIR GROUP S.L

<https://paxspain.com/>
info@ventilairgroup.es

sales@ventilairgroup.es

* Data is subject to changes without notification due to product improvement